

Short pitch conveyor chain with attachments

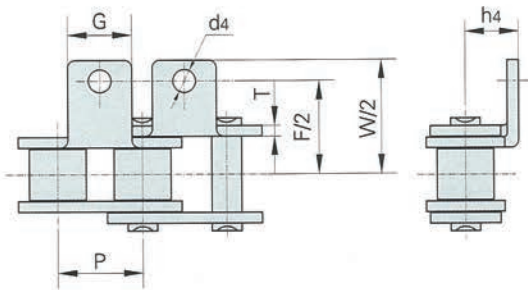

A-1



K-1

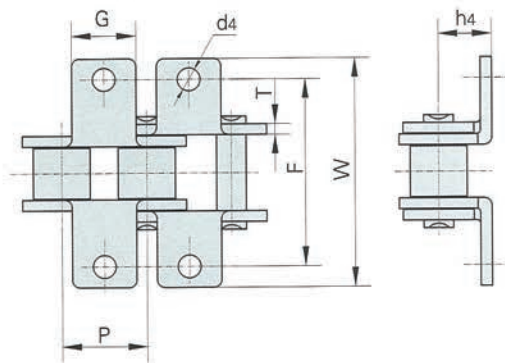

DIN/ISO Chain No.	ANSI Chain No.	P	G	F	W	T	h4	d4
		mm	mm	mm	mm	mm	mm	mm
04C	25	6.350	5.6	13.80	23.2	0.80	4.30	3.4
06C	35	9.525	7.9	19.00	28.60	1.30	6.35	3.4
08A	40	12.700	9.5	25.40	35.20	1.50	7.90	3.4
085	41	12.700	9.5	24.00	33.4	1.30	6.90	3.6
10A	50	15.875	12.7	31.75	46.2	2.03	10.30	5.5
12A	60	19.050	15.9	38.10	55.6	2.42	11.90	5.5
16A	80	25.400	19.1	50.80	64.8	3.25	15.90	6.8
20A	100	31.750	25.4	63.50	87.3	4.00	19.80	9.2
24A	120	38.100	28.6	76.20	108.5	4.80	23.00	9.8
28A	140	44.450	34.9	88.90	123.0	5.60	28.60	11.4
32A	160	50.800	38.1	101.60	142.8	6.40	31.75	13.1
40A	200	63.500	50.8	127.00	179.0	8.00	42.88	16.3
*06B		9.525	8.0	19.04	27.0	1.30	6.50	3.5
08B		12.700	9.5	25.40	36.4	1.60	8.90	4.5
10B		15.875	14.3	31.75	44.6	1.70	10.31	5.3
12B		19.050	16.0	38.10	52.4	1.85	13.46	6.4
16B		25.400	19.1	50.80	72.6	3.10	15.88	6.4
20B		31.750	35.0	63.50	100.5	3.50	19.80	9.0
24B		38.100	30.0	76.20	108.4	4.80	26.67	10.5
28B		44.450	35.0	88.90	123.0	6.00	28.58	13.1
32B		50.800	38.1	101.60	142.8	6.00	31.75	13.1

*Straight side plates

Short pitch conveyor chain with attachments

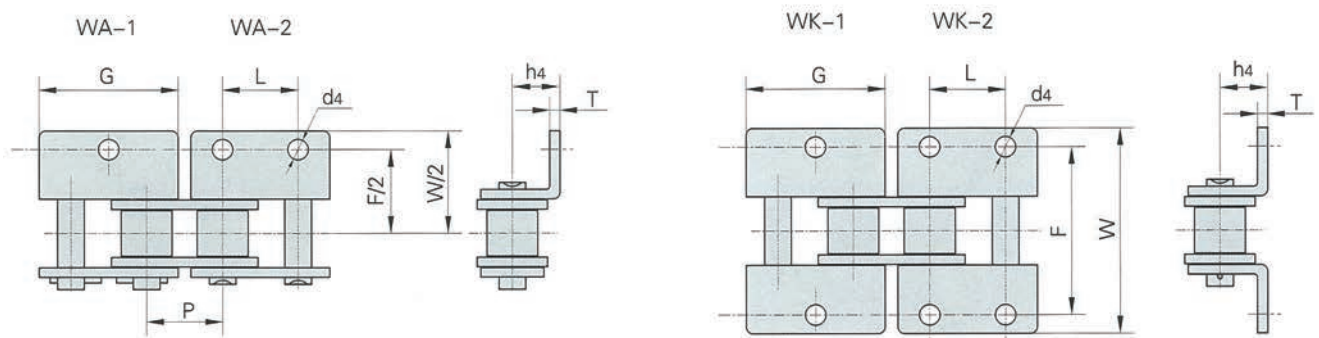

DIN/ISO Chain No.	ANSI Chain No.	P	G	L	F	W	T	h4	d4
		mm	mm	mm	mm	mm	mm	mm	mm
04C	25	6.350	11.41	6.350	13.80	23.2	0.80	4.30	3.4
06C	35	9.525	17.32	9.525	19.00	28.6	1.30	6.35	2.8
08A	40	12.700	23.00	12.700	25.40	35.6	1.50	7.90	3.4
085	41	12.700	22.30	12.700	24.00	35.0	1.30	7.20	4.85
10A	50	15.875	28.80	15.875	31.75	46.8	2.03	10.30	5.5
12A	60	19.050	34.65	19.050	38.10	56.4	2.42	11.90	5.5
16A	80	25.400	45.90	25.400	50.80	73.2	3.25	15.90	6.8
20A	100	31.750	57.65	31.750	63.50	89.8	4.00	19.80	9.2
24A	120	38.100	69.30	38.100	76.20	108.8	4.80	23.00	9.8
28A	140	44.450	80.45	44.450	88.90	123.0	5.60	28.60	11.4
32A	160	50.800	92.00	50.800	101.60	142.8	6.40	31.75	13.1
40A	200	63.500	115.5	63.500	127.00	179.0	8.00	42.88	16.3
*06B		9.525	17.72	9.525	19.04	27.0	1.30	6.50	3.5
08B		12.700	24.00	12.700	25.40	36.4	1.60	8.90	4.3
10B		15.875	29.58	15.875	31.80	44.6	1.70	10.31	5.3
12B		19.050	34.05	19.050	38.10	52.4	1.85	13.46	6.4
16B		25.400	46.40	25.400	50.80	72.6	3.10	15.88	6.4
20B		31.750	58.10	31.750	63.00	100.5	3.50	19.80	9.0
24B		38.100	71.30	38.100	76.20	108.4	4.80	26.67	10.5
28B		44.450	81.1	44.450	88.90	123.0	6.00	28.58	13.1
32B		50.800	92.8	50.800	101.60	142.8	6.00	31.75	13.1

*Straight side plates

Short pitch conveyor chain with attachments



SA-1/M1 one side



SK-1/M1 both sides

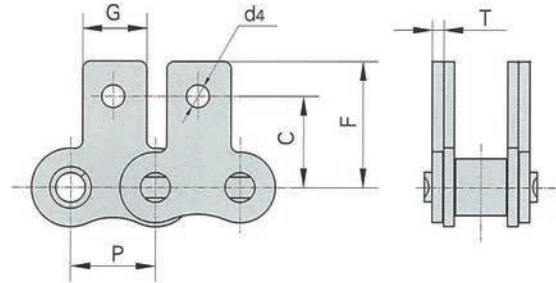
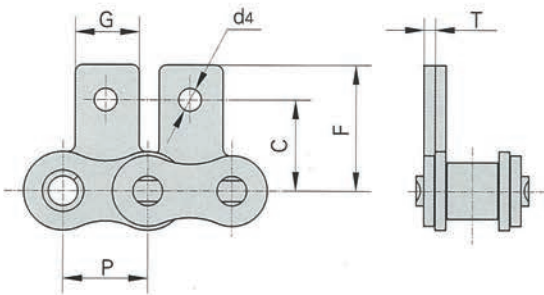

DIN/ISO Chain No.	ANSI Chain No.	P	G	C	F	T	d4
		mm	mm	mm	mm	mm	mm
04C	25	6.350	5.6	7.95	11.7	0.8	3.4
06C	35	9.525	7.9	9.50	14.55	1.30	3.4
08A	40	12.700	9.5	12.70	19.05	1.50	3.4
085	41	12.700	9.5	11.85	16.55	1.30	3.6
10A	50	15.875	12.7	15.90	25.25	2.03	5.5
12A	60	19.050	15.9	18.30	29.33	2.42	5.5
16A	80	25.400	19.1	24.60	34.70	3.25	6.8
20A	100	31.750	25.4	31.80	43.30	4.00	9.2
24A	120	38.100	28.6	36.50	51.60	4.80	9.8
28A	140	44.450	34.9	44.50	62.00	5.60	11.4
32A	160	50.800	38.1	50.80	69.85	6.40	13.1
40A	200	63.500	50.8	63.50	88.90	8.00	16.3
*06B		9.525	8.0	9.52	13.50	1.30	3.5
08B		12.700	9.5	13.35	18.90	1.60	4.3
10B		15.875	14.3	16.50	22.95	1.70	5.3
12B		19.050	16.0	21.45	28.60	1.85	6.4
16B		25.400	19.1	23.15	34.00	3.10	6.4
20B		31.750	35.0	30.50	45.70	3.50	9.0
24B		38.100	36.0	42.70	61.50	4.80	10.5

*Straight side plates

Short pitch conveyor chain with attachments

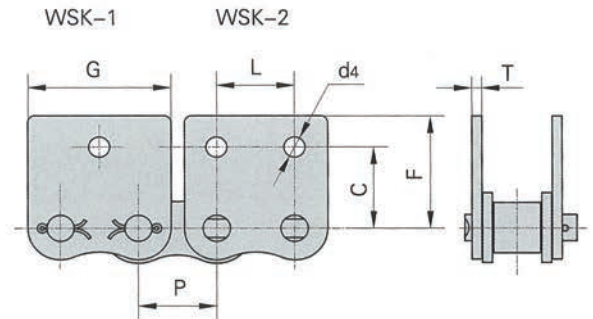
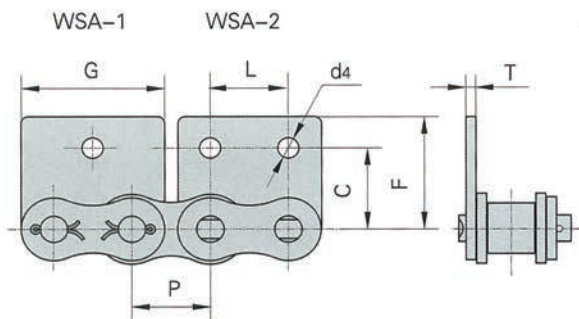

DIN/ISO Chain No.	ANSI Chain No.	P	G	L	C	F	T	d4
		mm	mm	mm	mm	mm	mm	mm
04C	25	6.350	11.41	6.350	7.95	11.70	0.80	3.4
06C	35	9.525	17.32	9.525	9.50	14.55	1.30	2.8
08A	40	12.700	23.00	12.700	12.70	17.40	1.50	3.4
085	41	12.700	21.20	12.700	11.85	16.55	1.30	3.6
10A	50	15.875	28.80	15.875	15.90	23.05	2.03	5.5
12A	60	19.050	34.65	19.050	18.30	26.86	2.42	5.5
16A	80	25.400	45.90	25.400	24.60	35.45	3.25	6.8
20A	100	31.750	57.65	31.750	31.80	44.00	4.00	9.2
24A	120	38.100	69.30	38.100	36.50	51.60	4.80	9.8
28A	140	44.450	80.45	44.450	44.50	62.00	5.60	11.4
32A	160	50.800	92.00	50.800	50.80	69.85	6.40	13.1
40A	200	63.500	115.5	63.500	63.50	88.90	8.00	16.3
*06B		9.525	17.72	9.525	9.52	13.50	1.30	3.5
08B		12.700	23.30	12.700	13.35	18.90	1.60	4.3
10B		15.875	29.58	15.875	16.50	22.95	1.70	5.3
12B		19.050	34.05	19.050	21.45	28.60	1.85	6.4
16B		25.400	46.40	25.400	23.15	34.00	3.10	6.4
20B		31.750	58.10	31.750	30.50	45.70	3.50	9.0
24B		38.100	71.30	38.100	42.70	61.50	4.80	10.5

*Straight side plates

Double pitch conveyor chain with attachments

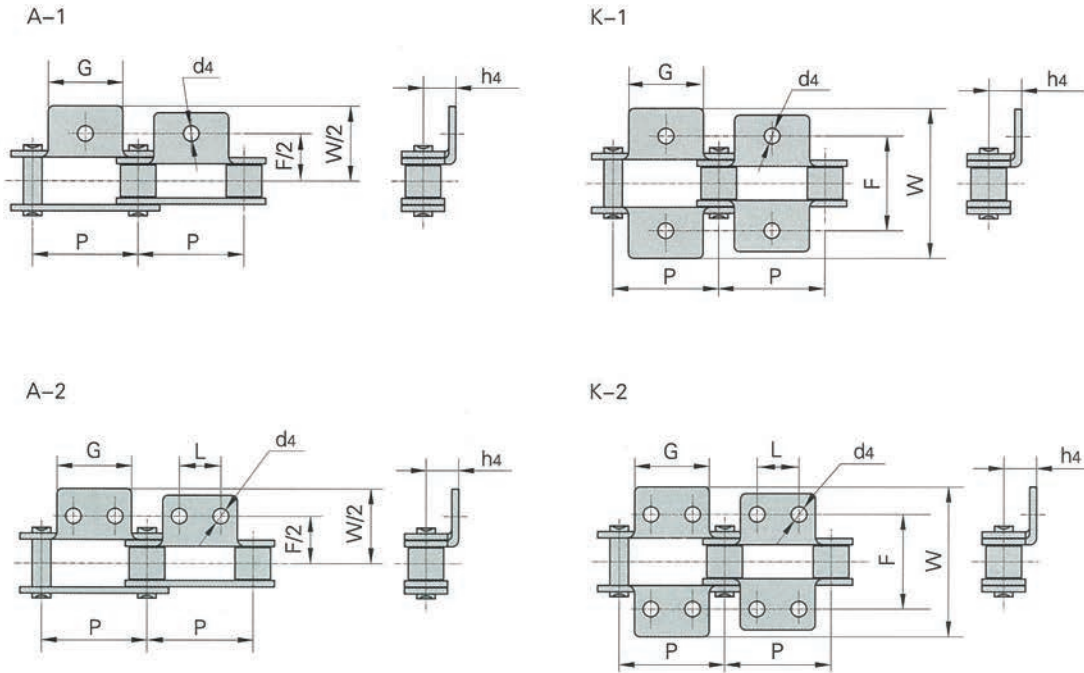

DIN/ISO Chain No.	ANSI Chain No.	P	G	L	F	W	h4	d4
		mm	mm	mm	mm	mm	mm	mm
C208A C208AL	C2040 C2042	25.4	19.1	9.5	25.4	39.6	9.1	3.4
C208B C208BL		25.4	23.2	12.7	25.4	39.6	9.1	4.5
C210A C210AL	C2050 C2052	31.75	23.8	11.9	31.8	49.0	11.1	5.5
C212A C212AL	C2060 C2062	38.1	28.6	14.3	42.9	67.8	14.7	5.5
C212AH C212AHL	C2060H C2062H	38.1	28.6	14.3	42.9	67.8	14.7	5.5
C216A C216AL	C2080 C2082	50.8	38.1	19.1	55.6	87.8	19.1	6.8
C216AH C216AHL	C2080H C2082H	50.8	38.1	19.1	55.6	87.8	19.1	6.8
C220A C220AL	C2100 C2102	63.5	47.6	23.8	66.6	107.5	23.4	9.2
C220AH C220AHL	C2100H C2102H	63.5	47.6	23.8	66.6	107.5	23.4	9.2
C224A C224AL	C2120 C2122	76.2	57.2	28.6	79.3	121.4	27.8	11.0
C224AH C224AHL	C2120H C2122H	76.2	57.2	28.6	79.3	121.4	27.8	11.0
C232A C232AL	C2160 C2162	101.6	76.2	38.1	104.7	151.6	36.5	13.1
C232AH C232AHL	C2160H C2162H	101.6	76.2	38.1	104.7	151.6	36.5	13.1